

FUSELAGE, TAIL & LANDING GEAR
 CONSTRUCTION OF WELDED CHROME
 MOLYBDENUM TUBING - FABRIC COVERED
 EXCEPT FOR AREAS SHOWN.
 WING CONSTRUCTION - SPRUCE SPARS
 AND PLYWOOD RIBS WITH INTERNAL
 WIRE BRACING - FABRIC COVERED

COLOR SCHEME: BOTH "IKE" & "MIKE"
 WHITE WITH BLACK LETTERING.

FABRIC COVERED
 TOP VIEW IS "IKE"

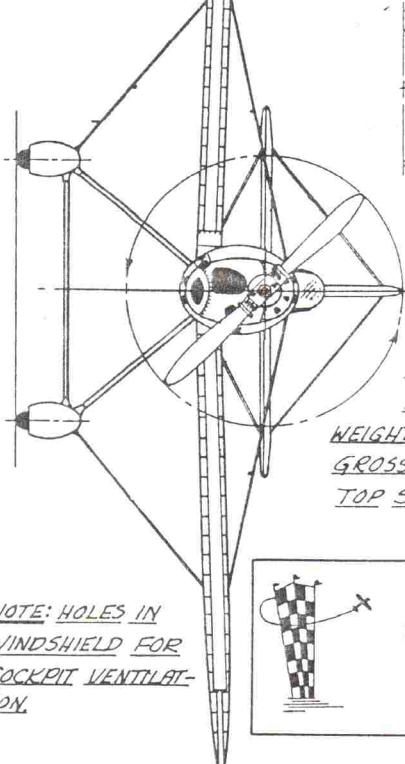

SPAN - 20'1"
 LENGTH - 17'
 WEIGHT EMPTY - 920 LB
 GROSS WEIGHT - 1200 LB
 TOP SPEED - 207 MPH

HOWARD
 DGA-4 "MIKE"
 &
 DGA-5 "IKE"

NOTE: HOLES IN
 WINDSHIELD FOR
 COCKPIT VENTILAT-
 ION.

ALUMINUM
 DECKING
 - H

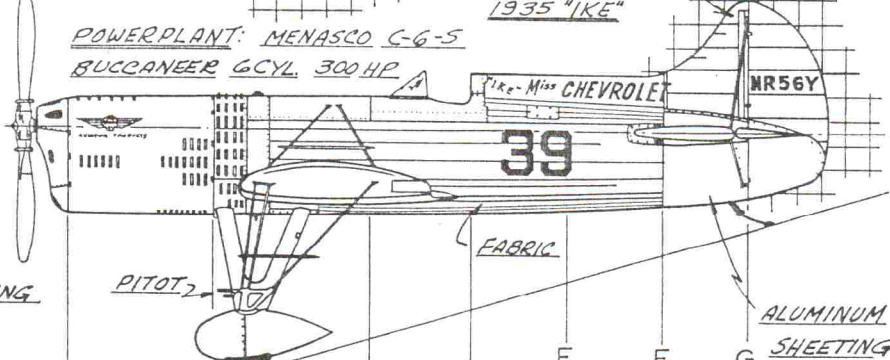
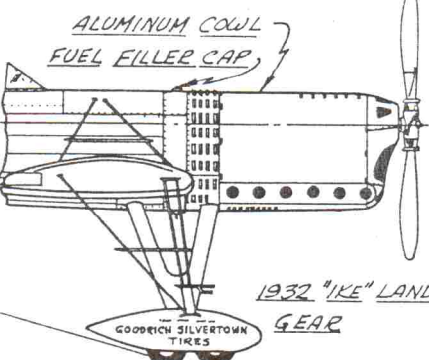
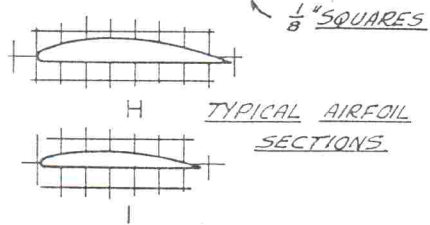

POWERPLANT: MENASCO G-6-5
 BUCCANEER 6 CYL. 300 HP

FABRIC COVERED
 1935 "IKE"

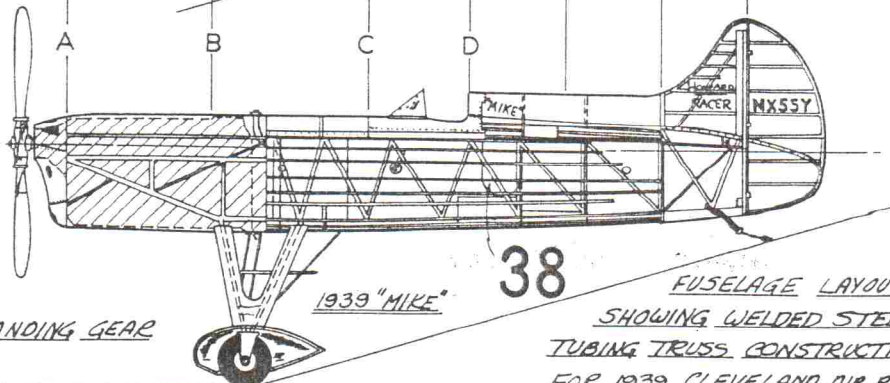
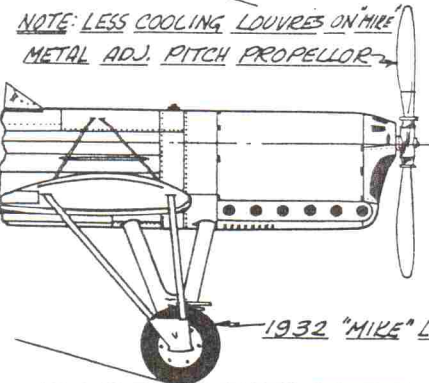

NOTE: LESS COOLING LOUVRES ON "MIKE"
 METAL ADJ. PITCH PROPELLOR

1935 "MIKE" CHEVROLET

39

ALUMINUM
 SHEETING

1932 "IKE" LANDING
 GEAR

PITOT

FABRIC

E

F

G

1932 "MIKE" LANDING GEAR

1939 "MIKE"

38

FUSELAGE LAYOUT
 SHOWING WELDED STEEL
 TUBING TRUSS CONSTRUCTION
 FOR 1939 CLEVELAND AIR RACE
 BOTH SHIPS PAINTED YELLOW
 BUT DID NOT FLY.

BUILT IN 1932 BY BEN HOWARD BOTH SHIPS PLACED
 IN VARIOUS THOMPSON TROPHY RACES 1932 THRU 1935.

SCALE 1/4" = 1'

